

CONGRATULATIONS ON YOUR PURCHASE OF OUR CAMERA

This product has been carefully inspected through rigid quality control before shipment. With reasonable installation and operation, it will provide years of reliable performance. Considering your investment, we understand you would like to know the full performance capability about the new product. Therefore, we need to recommend that you read the installation and operation manual thoroughly before attempting to install and operate the product.

IMPORTANT INFORMATION BEFORE INSTALLATION

PLEASE read and observe all instructions and warnings contained in this manual. Retain the original manual for future reference. When unpacking your new product, first please compare the received items with your order list, second check for damaged items. If there is anything missing or damage in evidence, please do not install or operate the product, then contact the dealer for assistance immediately. Never try to service this product by yourself. Opening the covers may expose you to dangerous power voltage or other hazards. For your protection, take a moment to complete the following product purchase information. The serial number of this product may be found on the cover of the unit. The serial number may be required by the factory when need service or technical support.

Model NO. TC101

Design for Water resistant (IP66) series CCD camera is based on professional video system processing capability. Interior key components adopt Japanese advanced charge coupled device (CCD) sensor and related peripheral IC. So the CCD camera has better performance as high sensitivity, sharpness, premium fidelity and low noise. Also it has electronic shutter, backlight compensation and auto white balance function. (For Color Camera only) Color temperature range for auto white balance is 2000K to 10,000 K degrees. (For Color Camera only) These cameras equipped with bracket, there is no extra bracket needed, very easy for installation.

1. This product is IP66 water resistant camera.
2. All service or maintenance should be made by qualified service personnel.
3. Storage temperature -30°C ~ 80°C.
4. All installation and service should conform to local codes.
5. Do not open the cover, it may expose you to power voltage and other hazard.
6. The equipment has been tested and pass the CE standard, which are designed to provide reasonable protection against harmful interference and be insusceptible to other radiating interference when operated in commercial environment. Therefore, the equipment can't also generate and cause any interference to radio communication.

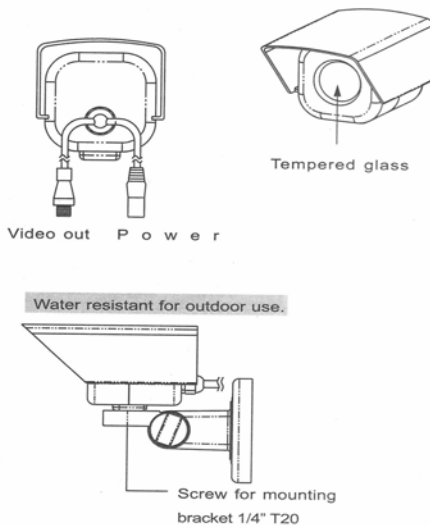

Model	Standard / High Resolution Color Camera	
Image device	1/3" Interline CCD SENSOR	
Picture elements	NTSC 512(H)×492(V)	NTSC 771(H)×492(V)
	PAL 512(H)×582(V)	PAL 753(H)×582(V)
Scanning system	NTSC standard 525 lines · 30 frames / sec PAL standard 625 lines · 25 frames / sec	
Synchronizing system	Internal	
Resolution	More than 330 TV Lines	More than 460 TV Lines
Electronic shutter control	Auto-Electronic shutter (1/60~1/100000) NTSC (1/50~1/100000) PAL	
Gamma	0.45	
Minimum illumination	1.0 LUX / F1.2	2.0 LUX / F1.2
Video output level	1Vp-p / 75 ohms	
Video S/N ratio	48dB (AGC OFF)	
White balance	Auto	
Operating temperature	-10°C ~ 50°C	
Storage temperature	-30°C ~ 80°C	
Power requirements	DC12V ± 10%	
Power consumption	120mA (MAX)	
Dimensions	70x60x86 mm	
Weight	400g	
Lens	Option	