

YOKO 1/3" B/W CCD CAMERA PC BOARD

MODEL: YK-3041A

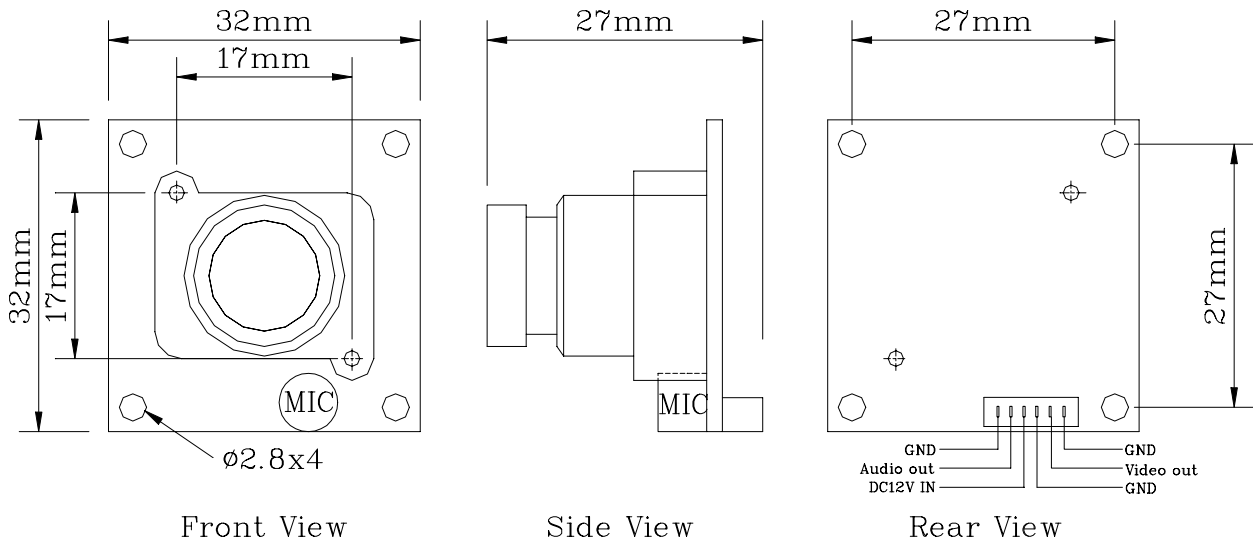

FEATURES

- ❑ B/W camera PCB Module with SONY 1/3" Super HAD CCD Sensor.
- ❑ Pixel number: EIA=270K / CCIR=320K.
- ❑ High sensitivity, low smear, high anti-blooming.
- ❑ Auto Electronic Shutter (AES), Auto Gain Control (AGC), built-in Audio.
- ❑ Economical, furnished with Board Lens.
- ❑ Furnished with 6 pins power & signals connecting wire.
- ❑ Small size: 32mm x 32mm.
- ❑ DC type, low power consumption.

SPECIFICATIONS (Note: Design and specifications are subject to change without prior notice.)

Image Pick-up Device	SONY 1/3" Super HAD CCD Sensor.
Effective Picture Elements	EIA: 510*492, CCIR: 500*582 (H*V)
Horizontal Resolution	420 horizontal TV lines
Minimum Illumination	0.1 LUX @ F2.0
S/N Ratio	More than 48dB
Auto Electronic Shutter	EIA: 1/60s ~ 1/100,000s, CCIR: 1/50s ~ 1/110,000s.
Auto Gain Control	Yes.
Scanning System	Interlace 2:1
Gamma Characteristic	0.45
Lens Furnished	Board Lens 3.6 mm / F2.0 (optional: 2.5 / 4.3 / 6.0 / 8.0 / 12 mm)
Synchronous System	Internal, Negative sync.
Video Output	1 Vp-p / 75 Ohms.
Audio output	2Vp-p / 50 Ohms
Power Supply	12V DC / 110 mA
Operating Temp.	-10 to 50 (14 to 122)
Dimensions	32 mm(L) * 32 mm (W) * 27 mm(H)
Weight	14.5 g